

THE POWER OF TWO

The easy entry into
pre-prepared mopping

THE POWER OF TWO

As a global leader in cleaning solutions, we firmly believe that every product we develop needs to make your daily business easier and more efficient. So, we asked ourselves, can we create a system that combines all the elements you need to push your business to next level? Yes, we can!

Welcome to UltraFlex DUO. The easy, efficient double-sided mopping system. Designed to increase your cleaning speed, hygiene, and flexibility at an excellent price-/performance ratio.

UltraFlex Duo. The power of Two.

Many sites
Many sectors
Many employees

The complexity and cost pressure of running a facility management business is very high.

What if there was a solution that significantly reduced costs and complexity?



Speed

**Pre-Prepared
mops**



Dose your mops once at the start of the day and you are ready to clean

**No wringing
or filling buckets**



No filling or emptying of buckets or wringing of mops after each use

**Increased
floor coverage**

40m²

Cover upto 40m² per mop before changing. Double the distance of single sided systems

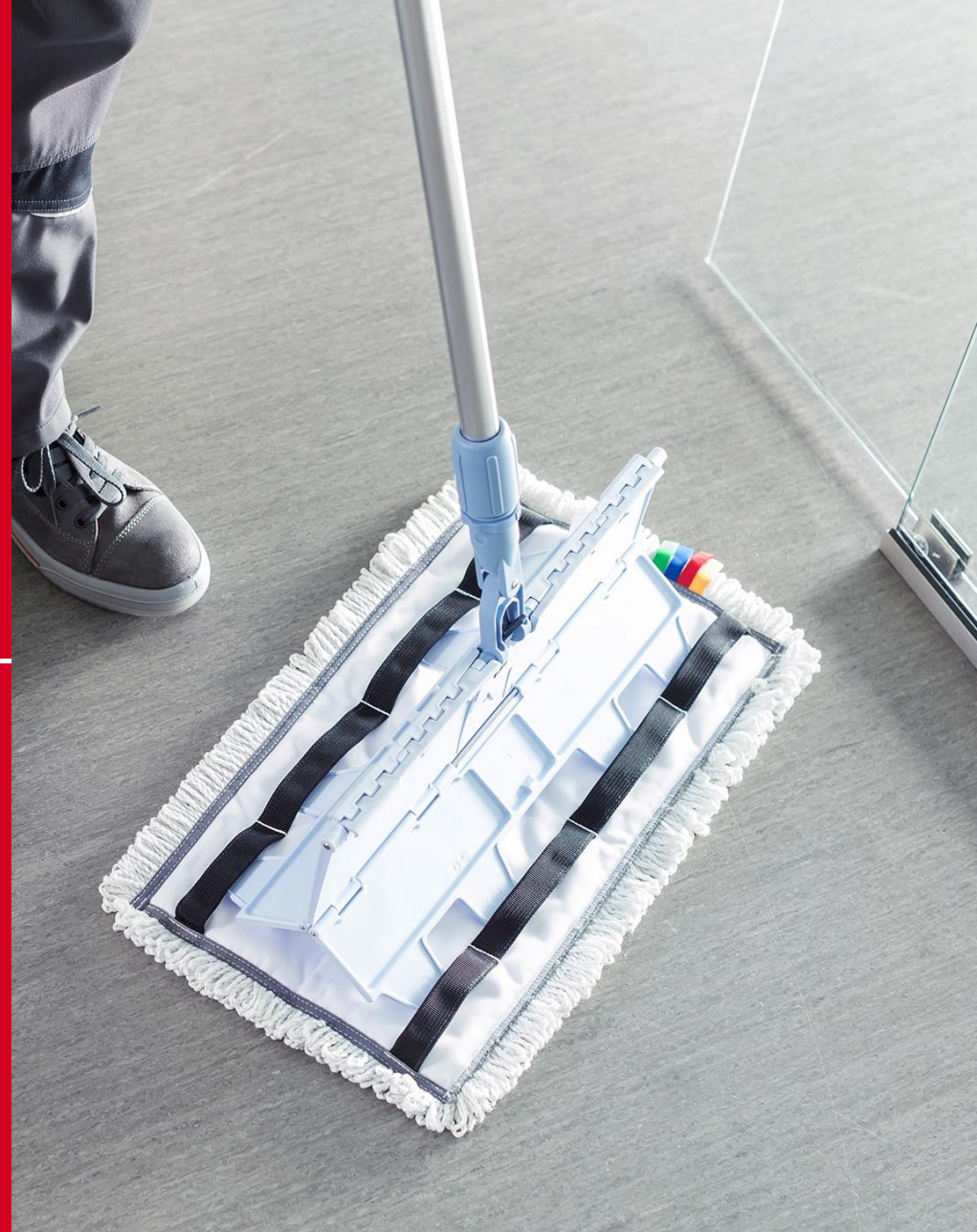



Hygiene

Pre-Preparation of mops

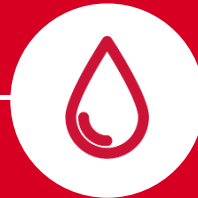

Batch dosing each mop with the correct amount of solution ensures only clean water is used on the floor, compared to used solution with bucket and press methods.

Proven bacteria & Virus removal

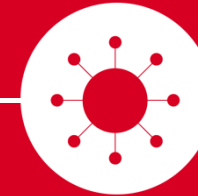

All mops are certified to remove up to 99.99% of virus and bacteria from floor surfaces

Microfibre cleaning



Pioneered by Vileda Professional and updated to meet the latest Nordic Swan ecological standards

Impact

Reduced complexity



Save time training staff as UltraFlex DUO is one system that can be used with all cleaning methods

Excellent price/performance ratio



Your investments are tailored to your needs with a choice of mops covering one, two or three year contracts

Low start up investments



Switching to pre-prepared mopping with UltraFlex Duo requires minimum investment in small laundry machines, frames and mops.



Speed **Hygiene**
THE
POWER
OF **The easy entry into**
pre-prepared mopping
Impact
TWO

UltraFlex Duo

LoopMax

High performance cleaning of structured floors

- Microfibre cleaning power with additional fringe for increased loose dirt pick up
- Up to 99.99% Bovine coronavirus removal from vinyl surfaces*
- Integrated cleaning zig zag pattern for improved stubborn dirt removal
- High durability up to 500 washes
- Awarded the Nordic Swan Ecolabel

*tested at a 3rd party lab



UltraFlex Duo LoopLite

Effective, all-purpose cleaning of structured floors

- Microfibre cleaning power
- Up to 99.99% bacteria removal*
- Medium durability up to 250 washes
- Awarded the Nordic Swan Ecolabel

*(P. aeruginosa & S. aureus on vinyl surfaces at a 3rd party lab)



UltraFlex Duo MicroMax

High performance cleaning of sealed and smooth floors

- Microfibre cleaning power with additional fringe for increased loose dirt pick up
- Up to 99.99% Bovine coronavirus removal*
- Added cleaning stripes for easy removal of stubborn dirt
- High durability up to 500 washes
- Awarded the Nordic Swan Ecolabel

*tested at a 3rd party lab



UltraFlex Duo MicroLite

Effective, all-purpose cleaning of sealed and smooth floors

- Microfibre cleaning power with additional fringe for increased loose dirt pick up
- Up to 99.99% bacteria removal*
- Added cleaning stripes for easy removal of stubborn dirt
- Medium durability up to 250 washes

*(P. aeruginosa & S. aureus on vinyl surfaces at a 3rd party lab)



UltraFlex Duo Mop Frame

Hygienic hands free removal

- 40cm frame width
- Easy hands free mop on (mop placed on the floor)
- Pull tab and integrated mop catch for hands free mop release
- Compatible with all UltraFlex Duo double sided mops

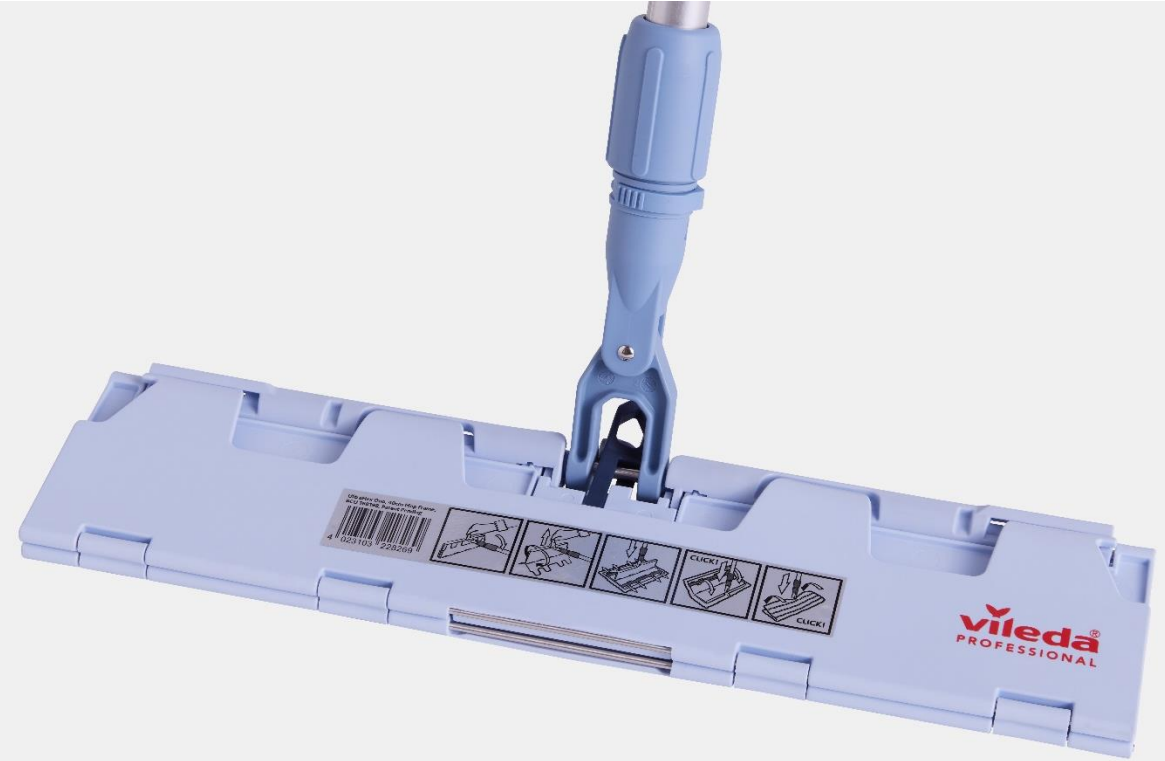

Duo Press Wringer

Double sided flat mop wringer

- Easy to insert frame into the press
- Ergonomic lever for maximum pressure with minimum effort
- Easy to clean, disinfect and sterilize in an autoclave
- 100 % Polypropylene chassis and stainless steel press mechanism
- Effective wringing of all UltraFlex Duo, Swep CE and Swep Duo



Origo 2

Press Support

Origo 2 double bucket flat mop performance

- Fits on Origo 2 B platform
- Compatible with Duo Press Wringer and Vertical press
- Double bucket cleaning
- Buckets and press sold separately



UltraFlex Duo Metal chassis

Compact and easy to manoeuvre

- Durable Zinc plating + powder coating
- 75mm castors with bumpers to protect walls
- Compatible with Duo Press Wringer and Vertical press
- Double bucket cleaning
- Buckets and press sold separately



Ultra for every demand.

Description	Size cm	Art.no Case	Packs/ case	Art.no Pack	Pieces/ Pack
UltraFlex Duo Frame	40 x 12 (closed)	168197	10	168198	1
UltraFlex Duo MicroLite	40	168199	20	168200	1
UltraFlex Duo MicroMax	40	168201	20	168202	1
UltraFlex Duo LoopLite	40	168203	20	168204	1
UltraFlex Duo LoopMax	40	168205	20	168206	1
Duo Press Wringer	n/a	168207	1	168208	1
O2 Press Support Kit	n/a	168280	1	168283	1
Metal Chassis Double Bucket Kit	n/a	168282	1	168284	1





Vileda Professional – Your leading partner for a clean and safe facility

- Everything we do grows from a constant dialogue with our customers. Based on more than 60 years experience in the business we are experts for the needs, challenges and conditions within professional cleaning. That is why we develop products and offer cleaning solutions that exceed our customers' expectations.
- Our innovative systems and superior services make our customers' daily work easier and more efficient.
- We commit ourselves to excellence – every Vileda Professional product offers the highest quality standards and minimizes the risks of your daily business.
- We make people work smarter, not harder: so, we focus on ergonomics, performance and design at every stage of the R&D phase, while using our patented technologies.
- We constantly strive for superior systems and services that support global sustainability.
- The Vileda Professional brand is part of the Freudenberg Group – a global technology group that strengthens its customers and society long-term through forward-looking innovations.



For more information visit our website
www.vileda-professional.com